



# VIDAR

## Installation Guide



This guide contains an overview of the hardware and required components, suggested scenarios and step-by-step guide for installation, and safety and maintenance instructions.

# VIDAR

## INSTALLATION GUIDE

Document version: 2026.01.20.

### Table of Contents

1.	INSTRUCTIONAL VIDEO SERIES.....	3
2.	HARDWARE OVERVIEW.....	5
3.	REQUIRED COMPONENTS.....	6
4.	RECOMMENDED INSTALLATION.....	7
5.	INSTALLATION STEPS.....	14
5.1.	POWER SPECIFICATIONS.....	14
5.2.	CABLE LAYOUTS.....	15
5.3.	HARDWARE INSTALLATION.....	16
1.1.	OPTIONAL WIRING.....	18
2.	SOFTWARE REQUIREMENTS.....	19
3.	ACCESSING THE CAMERA.....	19
4.	SAFETY.....	21
5.	MAINTENANCE / STORAGE.....	22
6.	APPENDIX.....	24
6.1.	RECOMMENDED POWER SUPPLY.....	24
6.2.	CABLE LAYOUTS.....	24
6.2.1.	POWER.....	24
6.2.2.	ETHERNET.....	25
6.2.3.	I/O (12 PIN).....	26
6.3.	JUNCTION BOX.....	27
6.4.	ADDING ALTERNATE IP ADDRESS.....	28
6.5.	MAGNETIC RESET.....	29
6.6.	POSITION OF THE STICKER.....	30
6.7.	COMPLIANCES.....	31
	CONTACT INFORMATION.....	33

## 1. INSTRUCTIONAL VIDEO SERIES

You may need these videos before/during the proper set-up and installation of the camera, it will provide you an extra help. It is recommended to watch it.

### 1. VIDAR ANPR/LPR Camera: Unboxing and Installation:

In this video, we guide you through the unboxing and installation of the VIDAR ANPR camera.

- What's in the box
- Cable types
- Connecting the bracket
- Connecting the power cable
- Connecting the ethernet cable
- Connecting the radar and external illuminator
- Turning the camera on.

[https://www.youtube.com/watch?v=v\\_6v2UZ5IHk&list=PLFiWaPY4v7LwJKqy5Jpdbq9YdhmgUIORZ&index=2](https://www.youtube.com/watch?v=v_6v2UZ5IHk&list=PLFiWaPY4v7LwJKqy5Jpdbq9YdhmgUIORZ&index=2)



## 2. VIDAR ANPR/LPR Camera: Setting the IP Address and Reaching the GUI:

In this video, we guide you through connecting the VIDAR ANPR camera to a PC or laptop/centralized router/switch to set it up by covering the following:

- Setting a static IP address
- Reaching the device's graphical user interface.

<https://www.youtube.com/watch?v=JQ3rIBzwGYU&list=PLFiWaPY4v7LwJKqy5Jpdbq9YdhmgUIORZ&index=3>



## 3) VIDAR ANPR/LPR Camera: Physical Installation:

In this video, we'll walk you through the following:

- The three types of installation available for VIDAR
- For which traffic situation each installation type is recommended
- The recommended settings for the three installation types
- Any additional advice that may come in handy.

<https://www.youtube.com/watch?v=QA8mKhLd8Mg&list=PLFiWaPY4v7LwJKqy5Jpdbq9YdhmgUIORZ&index=5>

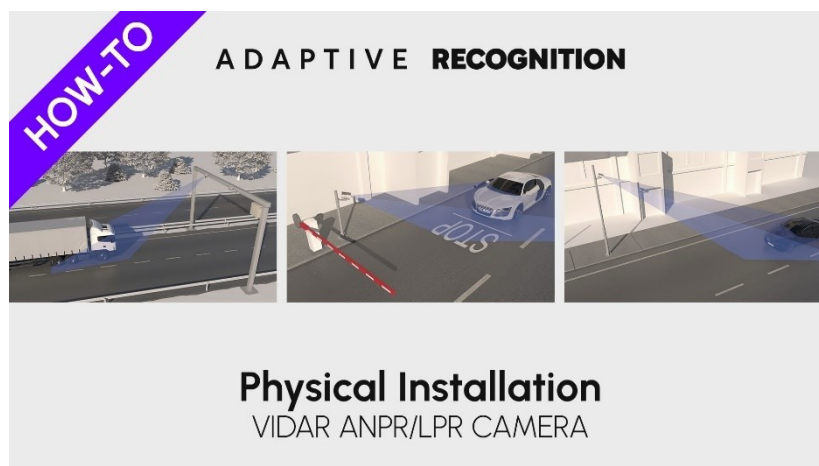

## 2. HARDWARE OVERVIEW

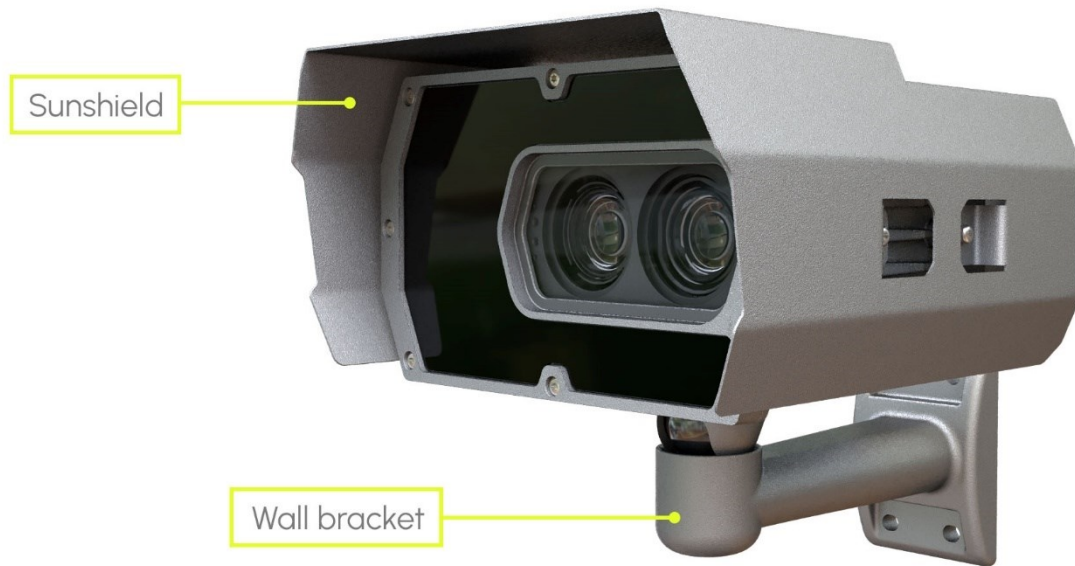

Camera with bracket

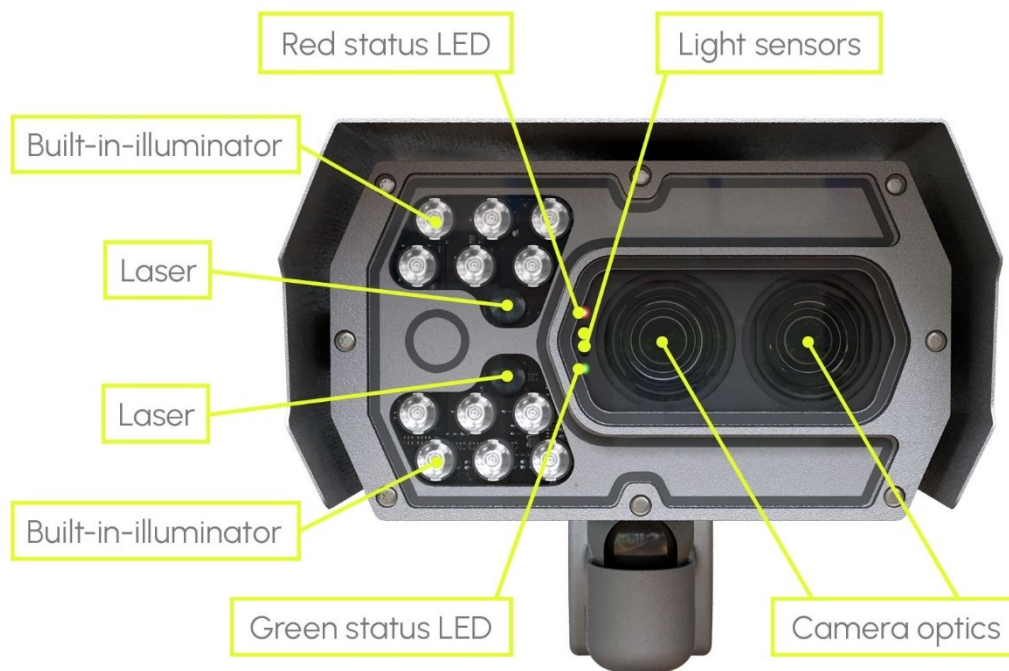

Camera front

### 3. REQUIRED COMPONENTS

1 Vidar ANPR/ALPR Camera

2 Bracket

OPTIONAL

3 Synchronized External Illuminator with Cable and Bracket

4 Power Cable (2 m)

5 Ethernet Cable (2 m)

6 GPIO Cable (2 m)



1

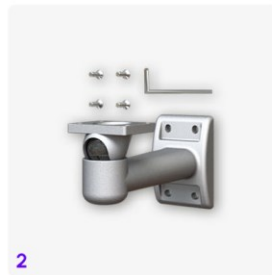

2



3

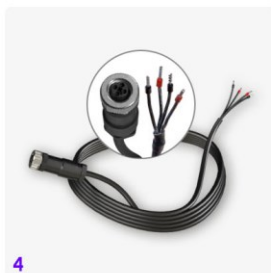

4

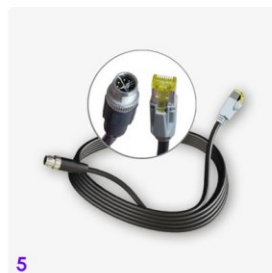

5

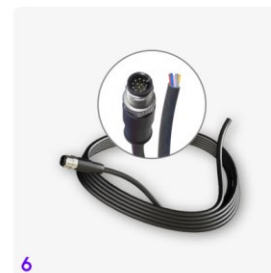

6

The box contains:

- Vidar camera
- Bracket

Optional parts:

- GPIO cable
- Synchronized External Illuminator

Required for camera operation: These are not included in the box, you can purchase it directly from Adaptive Recognition.

- Power cable
- Ethernet cable

Assets needed:

- Size 3 Allen key
- PC to reach web interface
- Magnet (min 1210 mT strength) to recover cameras when IP is lost

## 4. RECOMMENDED INSTALLATION

1. Please make sure that the camera is installed centered and it does not roll neither to the left nor right.



Correct camera position

Do not rotate the camera any direction from the horizontal position

**Roll must be 0°.** You can check the ROLL on the camera GUI here: **(Maintenance > Sensors)**

ADAPTIVE RECOGNITION	
EN	
2023.3.1-1207	
VIDAR SMART > MAINTENANCE > SENSORS	
SENSORS	
HORIZON (CAMERA)	
Tilt: -36.8°	
Roll: 0.0°	
LIGHT SENSOR / TEMPERATURE	
2719.00 lux	
28.00 °C	

Software Version: 2023.3.1-1207 Copyright © 1993-2023 Adaptive Recognition Hungary. All rights reserved.

2. Connect the cables to the designated connectors. Seal the unused cable endings with end sleeves before connecting to power!

3. Make sure the connecting cable does not lead rainwater drops into the camera housing!

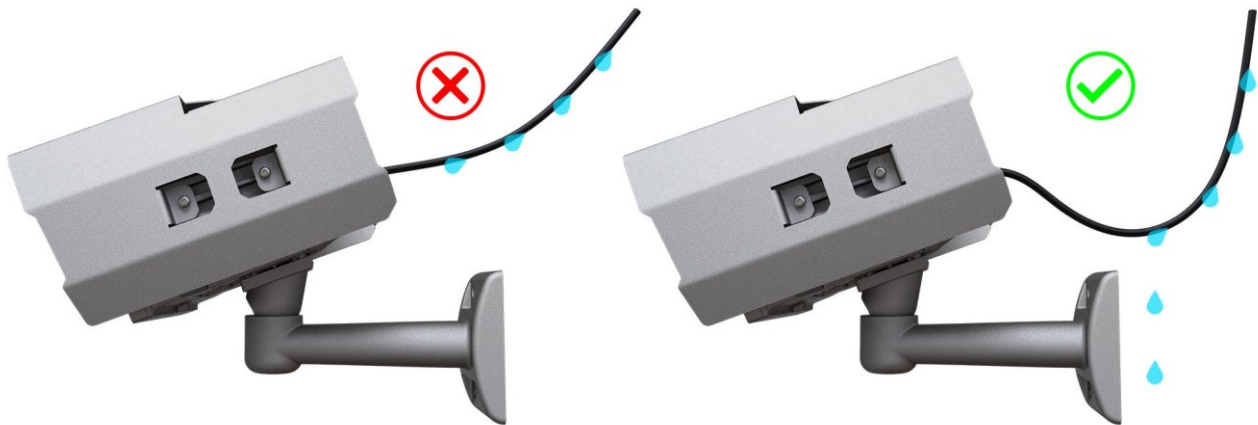
**! Important!**

Route the cable according to the image to avoid collecting rainwater at the socket. Failures caused by inappropriate installation will result in **a loss of warranty**.

4. Water may enter into the camera inside through not properly sealed connectors. To maintain the camera's watertightness please make sure that connected cables are tightened properly and the unused connectors are capped.

**! Important!**

If the waterproof cover is not used, it will result in a loss of warranty!

5. Please note that cameras installed inadequately may underperform in reading accuracy and vehicle detection.
6. Avoid east-west orientation of the camera. Sun can make reading difficult at certain times of the day.

7. The camera should be lowered below the horizon.
8. The number plate should be in the center of the image/lane when monitoring 1 lane.
  - Path: BASIC SETUP > LIVE VIEW > EXTENSIONS

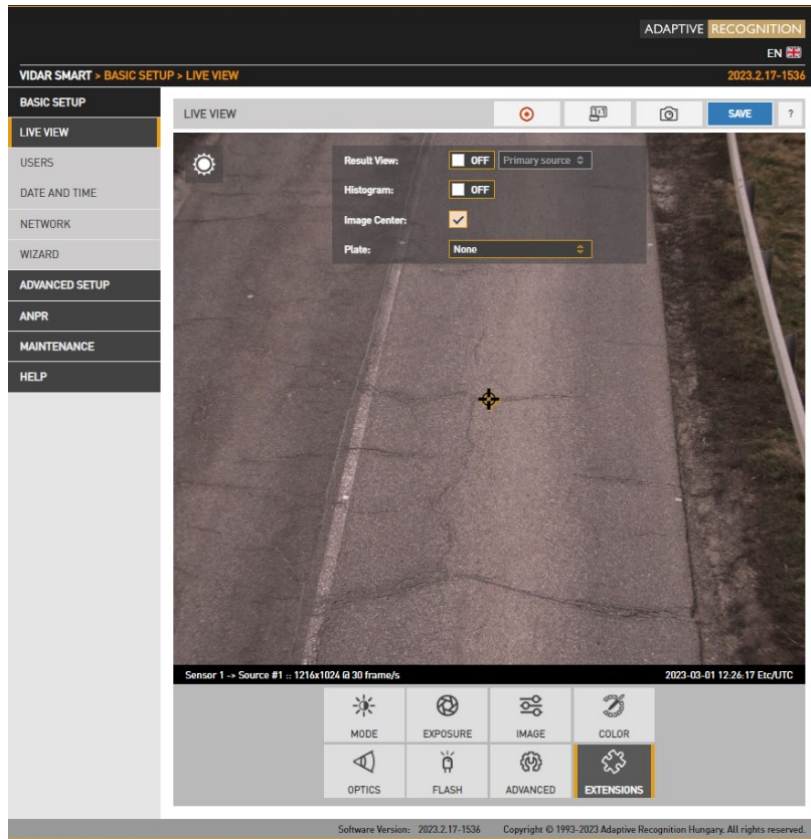

9. License plates should appear around the center of the image when monitoring 2 lanes (5MPx).
  - Path: BASIC SETUP > LIVE VIEW > EXTENSIONS

**10. Overhead installation** - when camera placed above the lane

- Vertical positioning (h):
  - typically 4-9 m above the lane
  - 2,5-4 m internal
- Horizontal positioning: center of the lane
- Vertical rotation - TILT ( $\alpha$ ): 20°-40°
- Typical range (r):
  - external: 15-20m
  - internal: 4-10m
- Camera should be pointed below the horizon
- Sun shouldn't be seen
- Typical application areas: external: highway, tolling - internal: parking

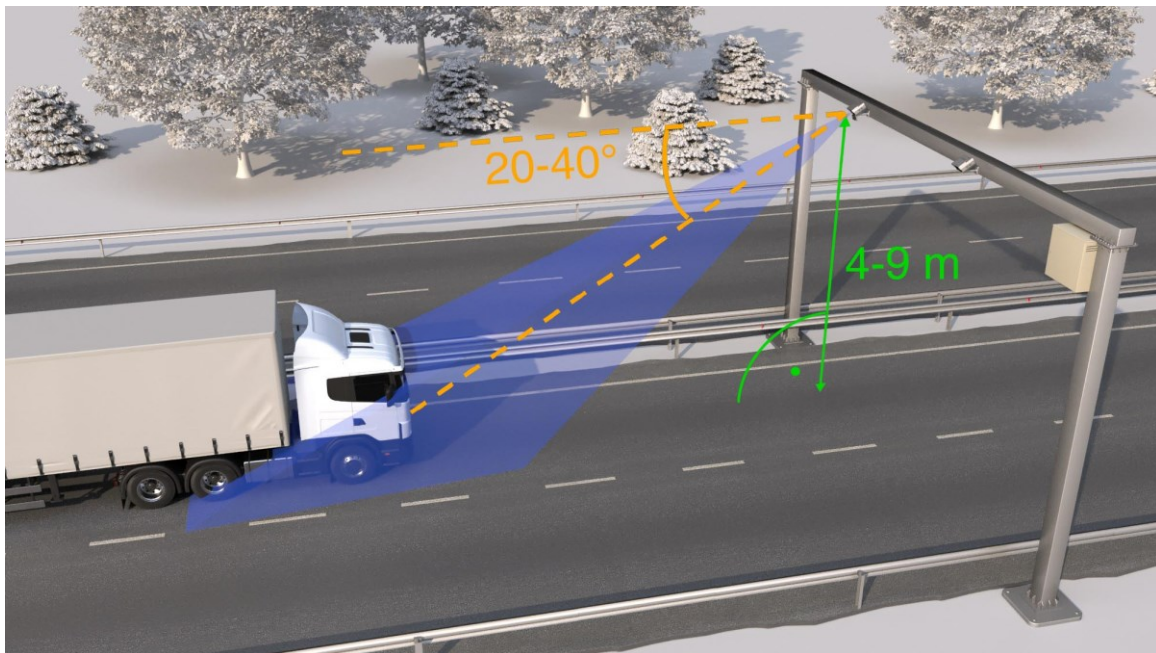

Overhead installation geometrics with range values

Here's an exact example of Overhead installation:

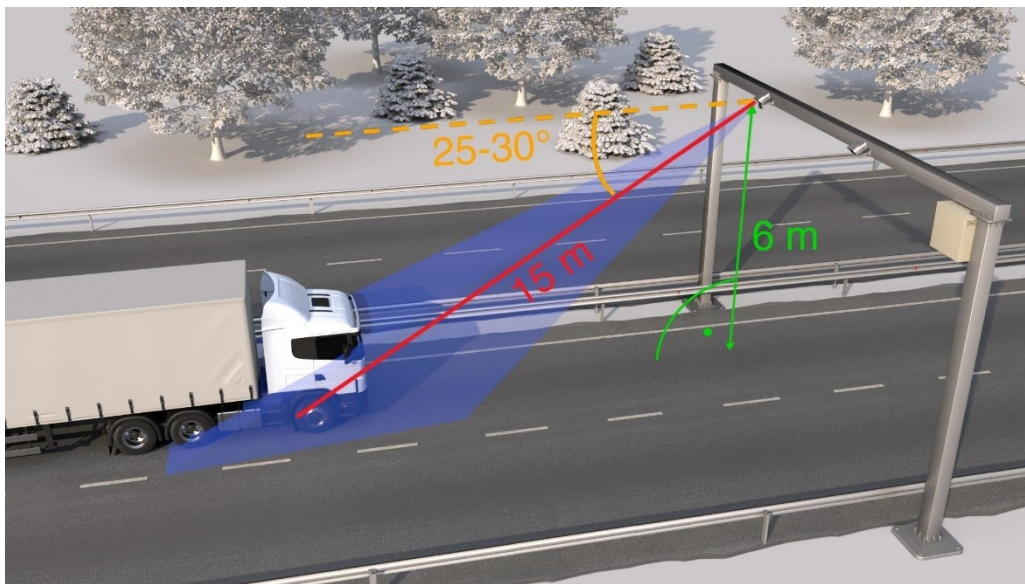

Overhead installation geometrics with exact values

II. **Transversal installation** - when the device is installed on a pole near the road and it has to be:

- Typical height (h): 4-8m
- Distance from the road (d): 1-2m
- Vertical rotation - TILT ( $\alpha$ ): 20°-40°
- Horizontal rotation - PAN ( $\beta$ ): 10°-20°
- Typical range (r): 15-20m
- Typical field of application: fixed installation on a road.

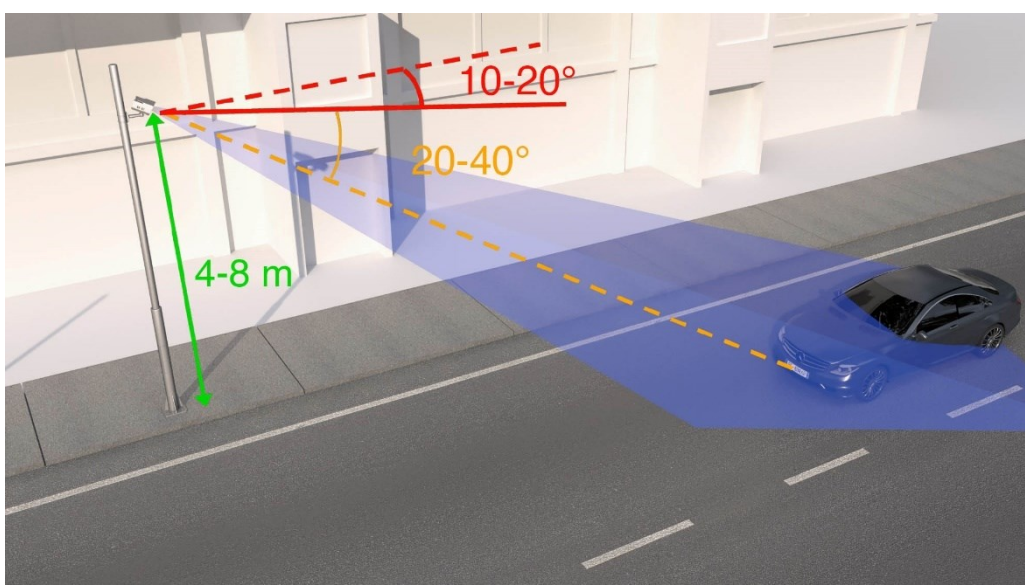

Transversal installation geometrics with range values

Here's an exact example of Transversal installation:

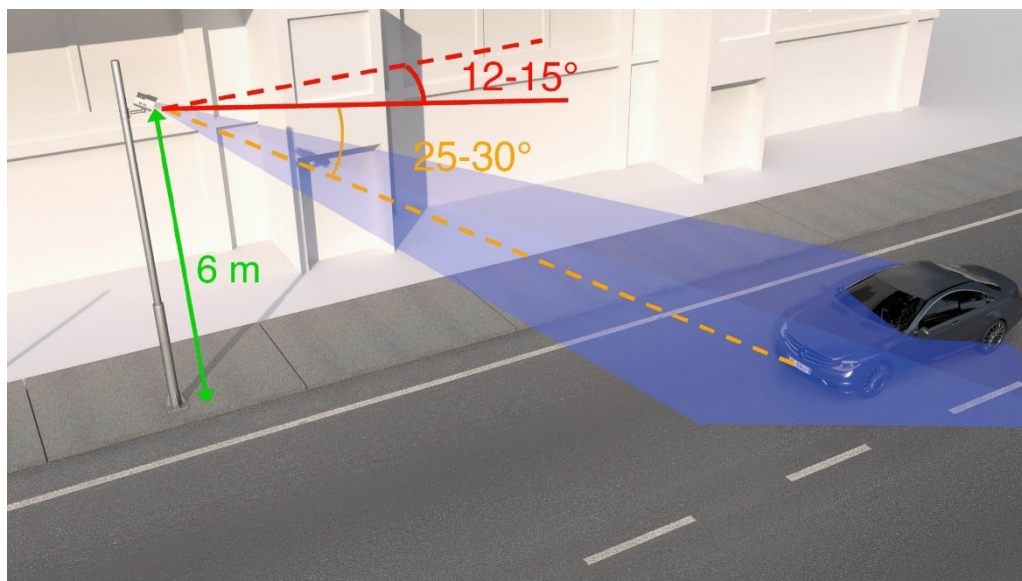

**Transversal installation geometrics with exact values**

12. **Access control** - Typical for access control

- Typical height (h): At least 1 meter above the headlights of the car
- Distance from the side of the road (d): Maximum 1 or 2 meters
- ANPR range: typically 4 m – 20 m
- Horizontal rotation - PAN ( $\beta$ ): max. 25°
- Vertical rotation: as low as possible, tilted slightly down
- Camera should be pointed on the road, below the horizon
- Sun should not shine in the camera or from behind the camera

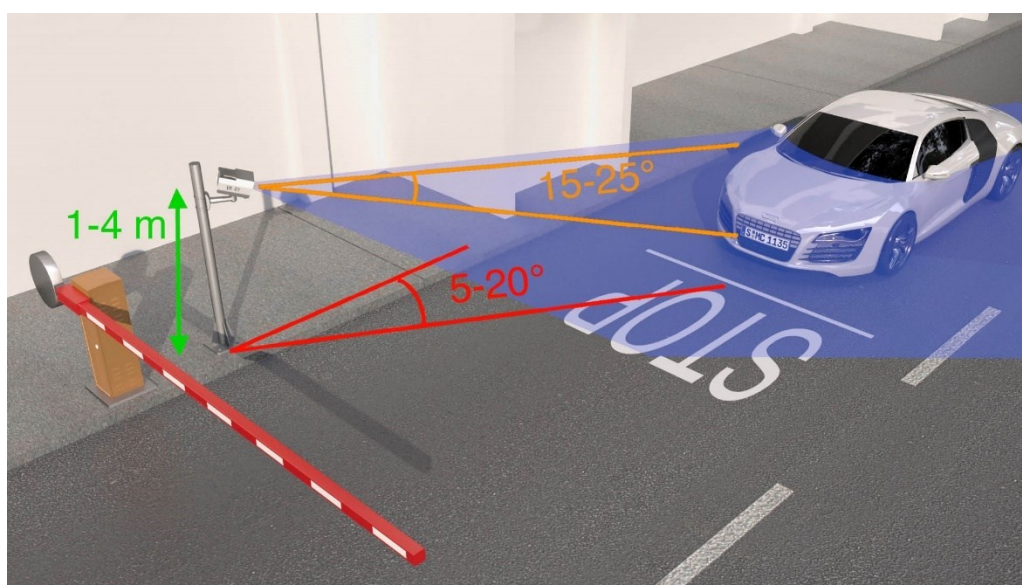

**Access control with range values**

Here's an exact example of Access control:

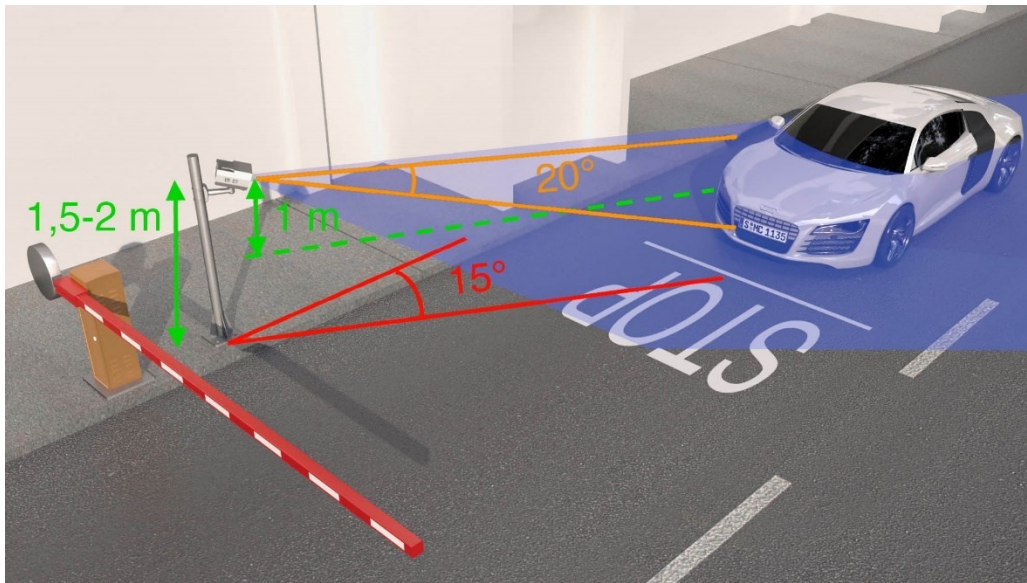

Access control with exact values

## 5. INSTALLATION STEPS

### 5.1. POWER SPECIFICATIONS

The required input voltage is model dependent, please use the proper input according to your model! Please consider voltage drop if you use cables!

	Camera with HDx sensor	Camera with FullHD sensor
<b>AC Input</b>	isolated 24 - 28V AC (sinusoidal)	
<b>Power (typical)*</b>	11 - 19 W	18 - 26 W
<b>Power (max. / max. with heating)</b>	25 / 51 W	26 / 52 W
<b>Over-current Protection</b>	by fuse	

\* - Depending on usage and configuration

Suggested power source with fuse protection:

AC/AC transformer:

Type: BREVE PSS 63/230/24V

Main parameters: 63W, 230Vac input, 24Vac output, 2.6A, IP30.

Procurement source: TME PSS63/230/24V

Product: Glass Fuse

Current Rating: 3.15A

Fuse Type: Time delay / Slow Blow

Fuse Size: 5 mm x 20 mm

Voltage Rating AC: 250 VAC

Mounting Style: Holder / Clips

Minimum Operating Temperature: -55 °C

Maximum Operating Temperature: + 125 °C

#### Note

To power off the camera (e.g. in case of relocation) please disconnect the power cord from the device by releasing the screw locking mechanism of the power connector, or disconnect the 24-28 VAC 50Hz power source from the camera power cord.

#### Important!

1. When performing a power reset, please wait at least 10 seconds before turning your power source on again.
2. Please make sure that the power cable is firmly connected to the camera before the power is applied when installing the device.

#### Important!

For safety reasons please use proper fuse\*\* protection on input power at the source.

\*\* - Please use the following fuse protection or equivalent:

Littelfuse Cartridge Fuses 02183.15MXP

Distributor: Mouser: 576-02183.15MXP

## 5.2. CABLE LAYOUTS

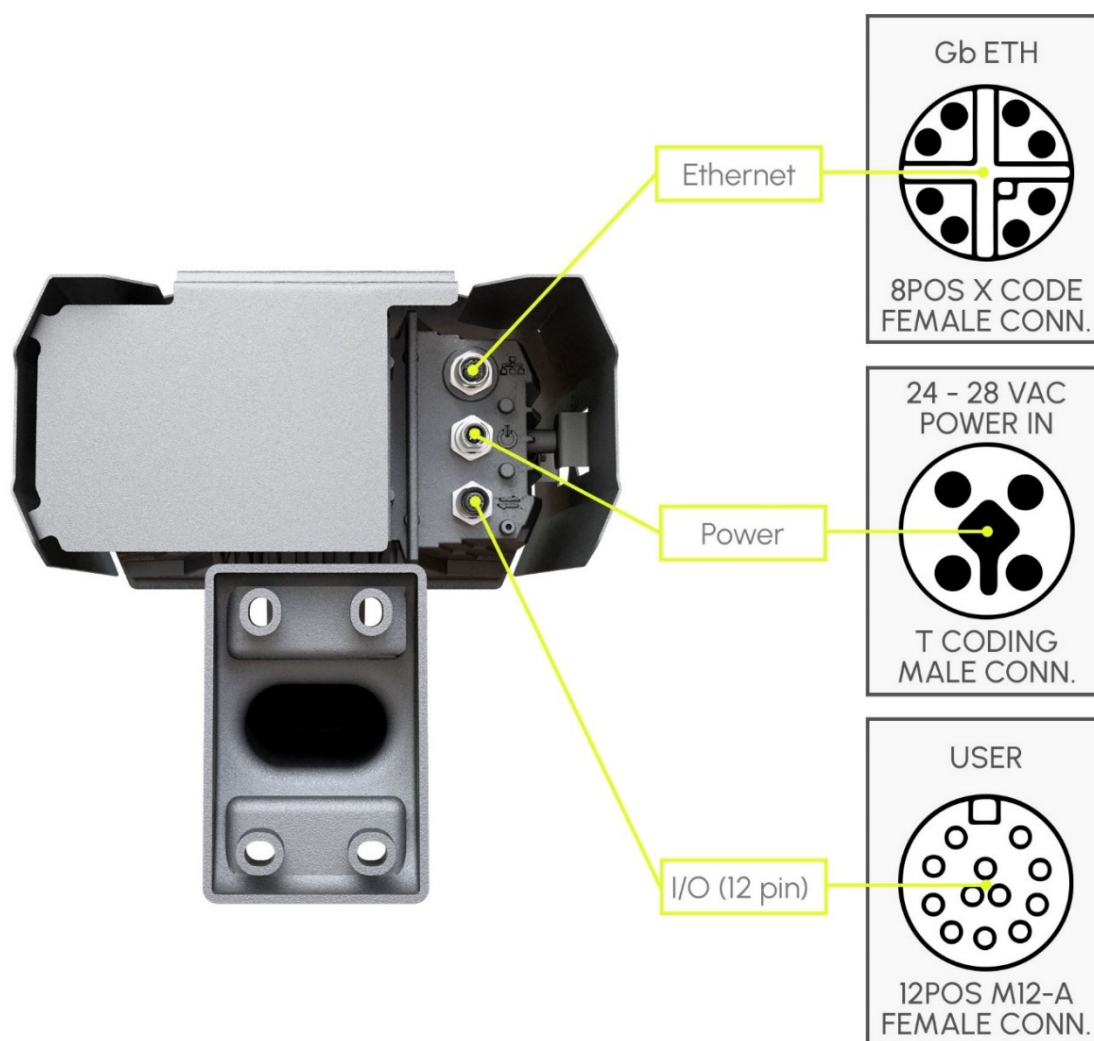

### Power

4 pos. M12 T coded, Male

Input voltage should be connected to AC1 and AC2. Both signals are connected to two pins (a and b) to allow for larger effective cable diameter/two wires for each potential. AC1\_a and AC1\_b are connected in the device. AC2\_a and AC2\_b are connected in the device.

See Appendix for more details at section [6.2.1](#)

### Ethernet

(8 pos. M12 X coded, Female) ... .. RJ45

Wire colours and RJ45 positions refer to those in the supplied standard ETH cable. Use quality outdoor Cat6 cable.

See Appendix for more details at section [6.2.2](#)

### 5.3. HARDWARE INSTALLATION

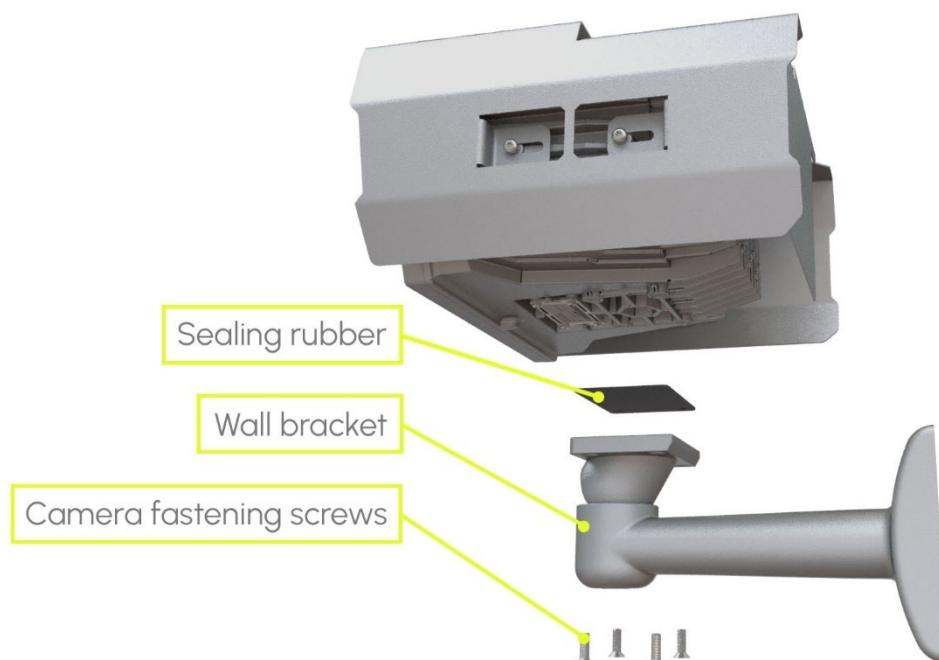

#### Bracket Details and Sizes

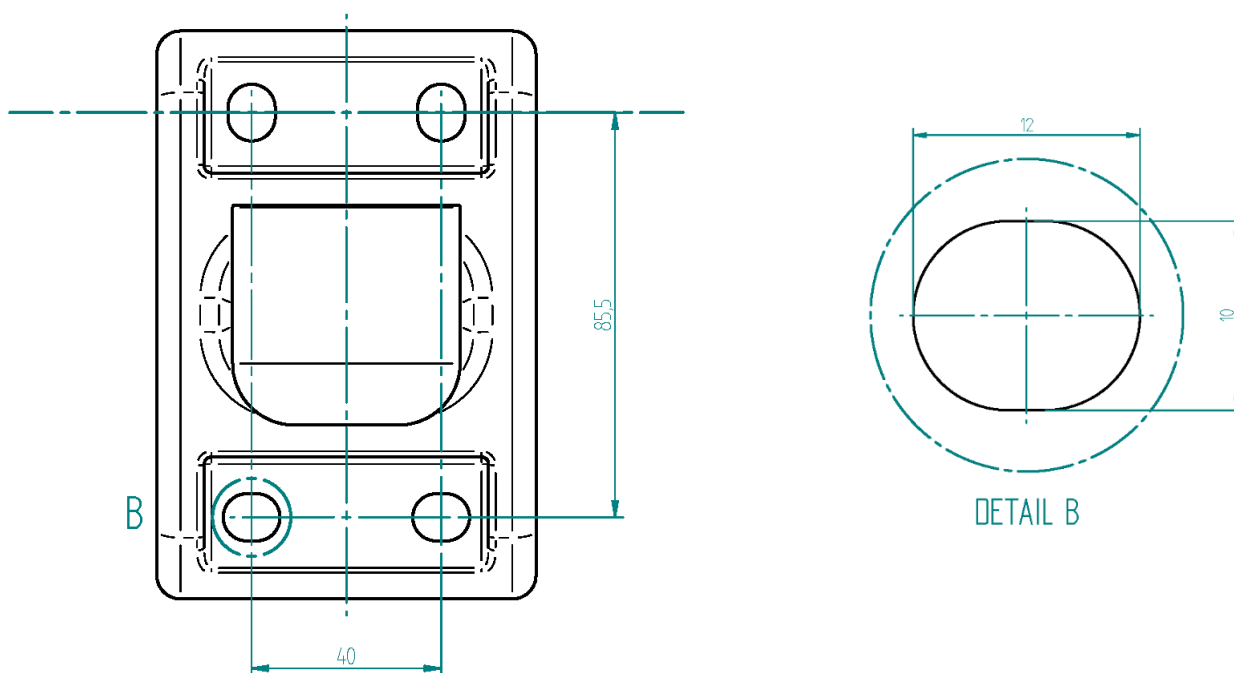

#### Note

To ensure proper mounting of the camera with bracket please use the largest possible fastener (e.g., fastening screw with DIA 8 mm).

### Adjust the bracket

1. Loosen the camera fastening screw on the bottom of the bracket. (Use size 5 Allen key).
2. Adjust the bracket into the desired position.

Tighten the screw back.

#### Note

Do not overtighten the screws.

### Mounting

The bracket can be mounted into different surfaces. Use appropriate screws for installation according to the mountable surface.

#### Note

Failures due to inappropriate installation void the warranty!

#### Important!

Only the camera's own screws should be used to secure the shield and the bracket. Other fasteners can damage the device, cause a danger, and result in the loss of warranty!

## 1.1. OPTIONAL WIRING

### I/O (12 pin)

12 pos. M12 A coded, Female

Connector pinout and wire color coding. Colours refer to those in the supplied standard I/O cable.

See Appendix for more details at section [6.2.3](#)

### Trigger specifications:

- **Input:** min. 5V, max. 12V
- **Pulse width:** min. 1 ms

**Logic Output:** min. 5V, max. 12V, max. 10mA

#### Note

Be aware of the polarity.

### Schematic for triggering:

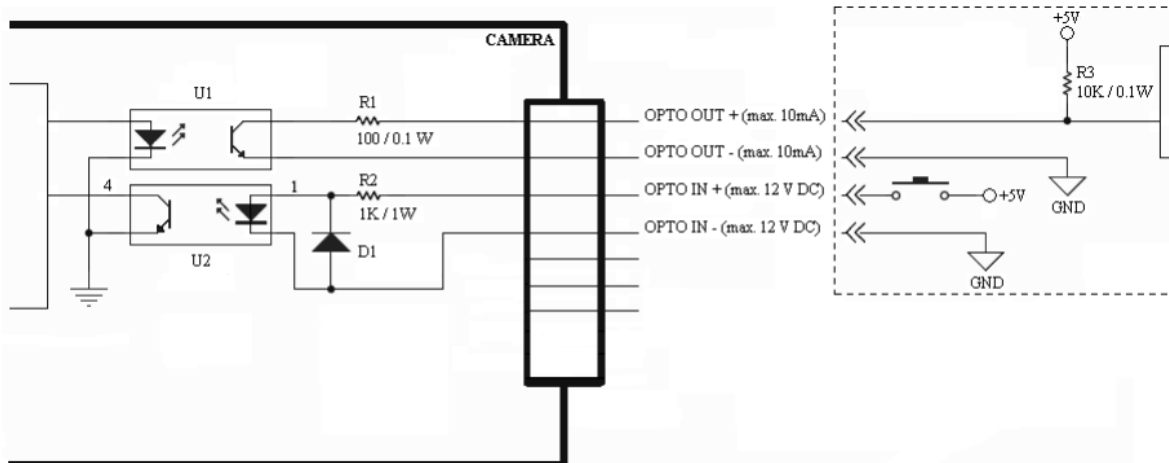

## 2. SOFTWARE REQUIREMENTS

The cameras are developed to operate without any kind of special software.

### Software requirements:

- For network setup, administrator (root) privileges are necessary.
- Web browser: Mozilla Firefox 52, Google Chrome 51.X.X.X or later editions. If it is possible, update your browser (Firefox or Chrome) to the newest available version.

#### Note

To enable all camera functions, enable JavaScript control in your browser.

## 3. ACCESSING THE CAMERA

### Steps of accessing the web interface of the camera from a browser:

1. Connect the camera to a computer or network switch, then power on the camera. After it is turned on, both status LEDs (red and green on the camera front) are turned on while the camera is booting. After finished, the green status LED flashes two times while the red one turns off signaling that the camera is ready for operation.



2. Enter an alternate IP address (or set your computer's IP) in the 192.0.2.x subnet – where x is an integer number between 1 and 254 **except 3** – with the subnet mask of 255.255.255.0.
3. For more information, see [Appendix](#).

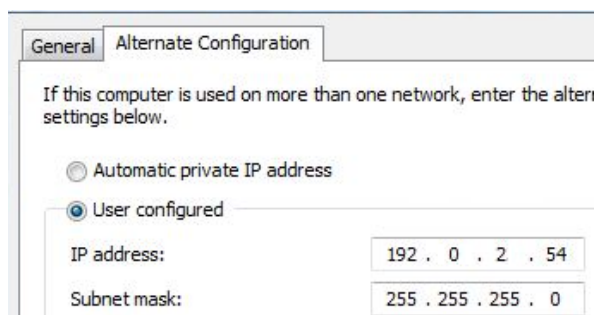

4. Use the ping command to test the communication with the camera:

**Windows:** C: \>ping -t 192.0.2.3

**Linux:** username@mylinux:~\$ ping 192.0.2.3

5. Soon, the ping package returns: **Reply from 192.0.2.3**. If not:

- first check the Ethernet LEDs at the PC or the switch side
- check whether the IP address is set correctly; the own IP address of the PC can be pinged.
- proxy is set in the browser or the browser is not set to offline.

If these obstacles are checked and there is still no reply, power off then on and enter the previous ping command again.

6. Start a browser then enter the default IP address of the camera into the address bar (**http://192.0.2.3**). After this, the camera starts with administrator privileges, ready to be set up and configured.

 Note

To enable all camera functions, enable JavaScript and ActiveX controls in your browser.

Next step is the camera configuration that is found in the User Manual:

<https://adaptiverecognition.com/doc/cameras/vidar-anpr-cameras/vidar-anpr-cameras-for-any-type-of-traffic-monitoring/>

How-to-video series on Youtube:

<https://www.youtube.com/playlist?list=PLFiWaPY4v7LwJKqy5Jpdbq9YdhmgUI0RZ>

## 4. SAFETY

### ! Important!

All screws should be hand-tightened! Do not overtighten the screws. Failures due to inappropriate installation void the warranty.

### ! Important!

The camera must only be installed on a stable surface!

### ! Important!

For cabling use quality, outdoor-certified cables! Improper cabling causes warranty to void!

### ! Important!

Water may enter into the camera inside through not properly sealed connectors. To maintain the camera's watertightness please make sure that connected cables are tightened properly and the unused connectors are capped.

### ! Important!

Seal the unused cable endings (end sleeves) before connecting to power in order to avoid damages due to short circuit!

### ! Important!

Do not look into the illumination unit directly from close range or for more than 100 seconds. Eyes can be damaged by not taking these precautions.

For detailed information see the User Manual:

<https://adaptiverecognition.com/doc/cameras/vidar-anpr-cameras/vidar-anpr-cameras-for-any-type-of-traffic-monitoring/>

or

Check our website: <https://adaptiverecognition.com/>

## 5. MAINTENANCE / STORAGE

The cameras are designed for 24/7/365 work for every weather condition and they do not need special maintenance. Please keep clean the camera front. During the cleaning process, avoid scratching the front cover.

Use only warm, soapy water for cleaning the camera! Some cleaning detergents may damage the camera, so we recommend using only common soap. Avoid to clean the camera with high-pressure water jets!

### Instruction for Cleaning Acrylic and Polycarbonate Sheets or Display Cover Glass

#### Materials Needed:

1. Synthetic microfiber wipes (without any added chemicals).
2. IPA/H<sub>2</sub>O\* mixture (details provided below).
3. Clean and dry hands or powder-free, disposable silicone rubber or PUR gloves.

*\*IPA (Isopropanol) and distilled water mixtures in ratios between 30/70% and 70/30%.*

#### Steps for Cleaning:

1. **Preparation:**
  - Wash and dry your hands or put on disposable, powder-free gloves.
  - Prepare the IPA/H<sub>2</sub>O mixture.
2. **Moisten the Wipe:**
  - Lightly spray the microfiber wipe with the IPA/H<sub>2</sub>O mixture. (Only 1-2 sprays needed).
3. **Wet Wiping:**
  - Begin cleaning by gently wiping the surface from the center towards the edges using the moistened wipe.
  - Use circular motions to cover the entire surface, moving from the center outwards.

#### 4. Dry Polishing:

- Immediately after wet wiping, use a dry microfiber wipe to polish the surface.
- Apply circular motions from the center outwards to remove any remaining streaks or stains.

#### 5. Repeat if Needed:

- If the surface remains contaminated, repeat the wet wiping and dry polishing process until the desired result is achieved.

#### Avoid using:

- Do not wash (recycle) wipes using softeners or detergents.
- Do not polish the surface using abrasive materials (glass/ceramic cleaner).
- Do not use regular 'kitchen wipes', as they might produce scratches.
- Non-woven polishing wipes similar to Katrin 45591 ([www.katrin.com](http://www.katrin.com) or ABSORMATTM ([www.crtoy.com](http://www.crtoy.com)), is also recommended.
- Do NOT apply any substances that claim to improve surface quality i.e., silicon sprays and 'lotus effect sprays'.
- It is forbidden to use solvents and detergents!

By following these steps, you should achieve a clean, streak-free surface.

Using a shield on the camera is recommended, as it can greatly help to cool the device properly in warm weather.

The cameras should be stored in low humidity environment in temperature range of -30 °C to + 55 °C. Always use the sealing caps on the connectors to keep the camera unit waterproof! If you miss to use it, the warranty will be void! The maintenance of the devices is recommended on a quarterly basis. In case of extreme weather conditions more often.

During the maintenance, make sure that:

- the camera operates properly,
- it is facing to the previously set direction,
- the fastening is not slack,
- the front of the camera and the camera itself is clean (no spider webs or any other contaminants inhibit the visibility),
- there are no strange circumstances (vapor, damage).

## 6. APPENDIX

### 6.1. RECOMMENDED POWER SUPPLY

Two types of power supply are recommended, one is an AC230V/AC24V transformer, the other is an AC230V/36V DC power supply. Both are suitable for powering a Vidar camera under suitable environmental conditions.

#### AC/DC power supply:

Type: Stontronics SRS-75-36

Main features: 75W, Universal AC input 100-240Vac, 36V DC output.

Procurement source: Farnell 3377270

#### AC/AC transformer:

Type: BREVE PSS 63/230/24V

Main features: 63W, 230Vac input, 24Vac output, 2.6A, IP30.

Procurement source: TME PSS63/230/24V

### 6.2. CABLE LAYOUTS

#### 6.2.1. POWER

4 pos. M12 T coded, Male

Pin1 and 2: GND

Pin3 and 4: +36 VDC

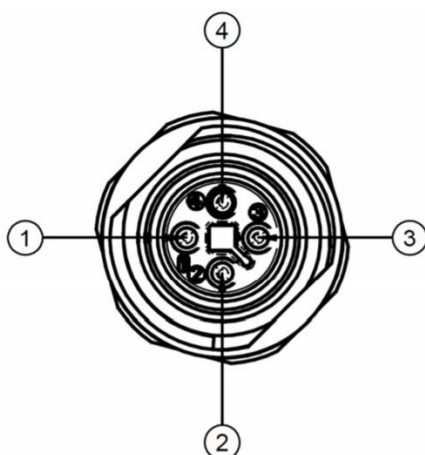

4 Pole Power Connector	
Pin	Function
1	AC_1
2	
3	AC_2
4	



Connecting the 36V DC power supply should be done as per the below wiring diagram:

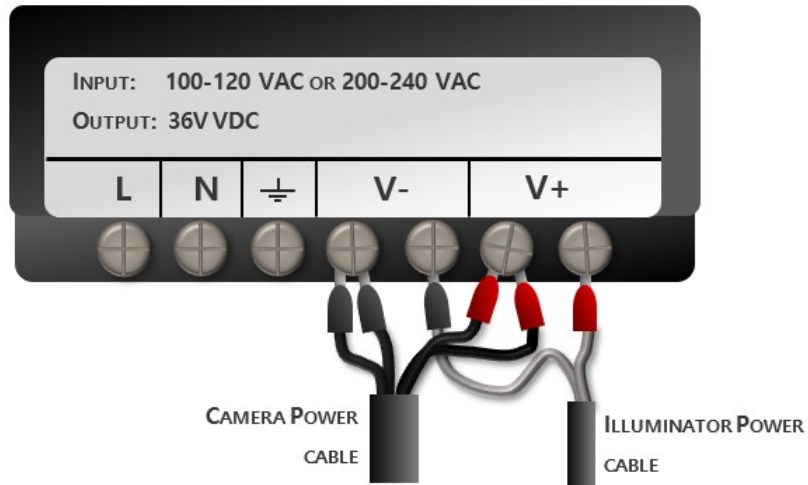

1. Connect Camera Power Cable black wires 1 and 2 to the power supply (V-).
2. Connect Camera Power Cable red wires 3 and 4 to the power supply (V+).
3. Connect the IR Power Cable black wire to power supply pin 5 (V-).
4. Connect the IR Power Cable red wire to power supply pin 7 (V+).

### 6.2.2. ETHERNET

(8 pos. M12 X coded, Female) ... RJ45

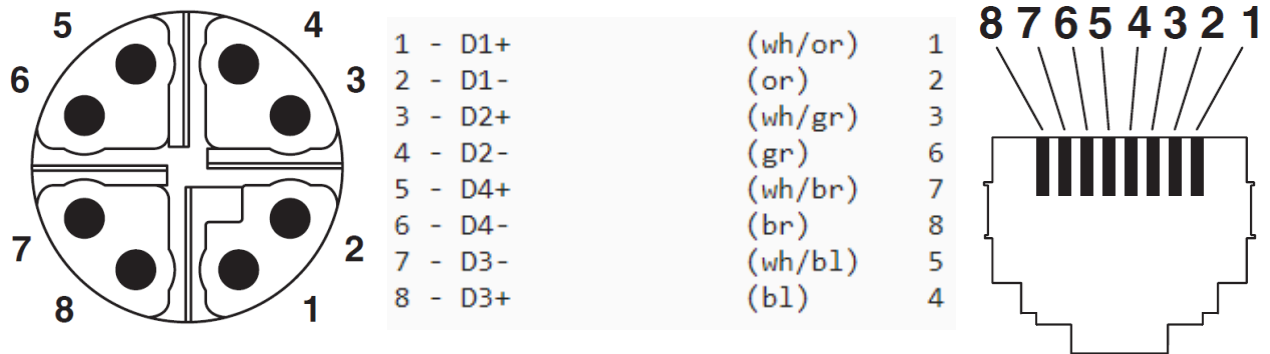

### 6.2.3. I/O (12 PIN)

12 pos. M12 A coded, Female

PIN	WIRE	FUNCTION
1	BROWN	OPTO_IO_G (default: OPTO_IN_G)
2	BLUE	TA_USER
3	WHITE	RB_USER
4	GREEN	ILL_STR
5	PINK	USB_GND (USB/UART/PWR GND)
6	YELLOW	USB_D_P
7	BLACK	USB_D_N
8	GRAY	USB_5V
9	RED	SW_12V_OUT
10	PURPLE	OPTO_OUT_S
11	GRAY/PINK	OPTO_OUT_G
12	RED/BLUE	OPTO_IO_S (default: OPTO_IN_S)



### 6.3. JUNCTION BOX

A 12-pin user cable (M12 binder female connector at one end, and a stripped end on the other) is required to connect the camera to the Junction Box. This I/O cable is not included by default with the camera. However, you can purchase it directly from Adaptive Recognition (PART #: COMBUY-OTH0326)

Camera Power Cable	Camera User Cable (12-pin)	Junction Box Camera Side	Junction Box User Side	User Cable
Red (#1 and #2)	-	1 - Power Output +	1 - Power Input +	24 V AC
Black (#3 and #4)	-	2 - Power Output -	2 - Power Input -	24 V AC
-	Grey/Pink	3 - Opto_Out_G	3 - Relay_NC	GP Out #1 GND
-	Purple	4 - Opto_Out_S	4 - Relay_NO	GP Out #1 Signal
-	Red/Blue	5 - Opto_In_S	5 - Relay_COM	GP In #1 Signal
-	Brown	6 - Opto_In_G	6 - Opto_In_S	GP In #2 Signal
-	Not Connected	7 - RS485 Term.	7 - Opto_In_G	Not Connected
-	White	8 - Serial_RX	8 - Serial_RX	User Serial RX
-	Blue	9 - Serial_TX	9 - Serial_TX	User Serial TX
-	Pink	10 - Serial_GND	10 - Serial_GND	User GND

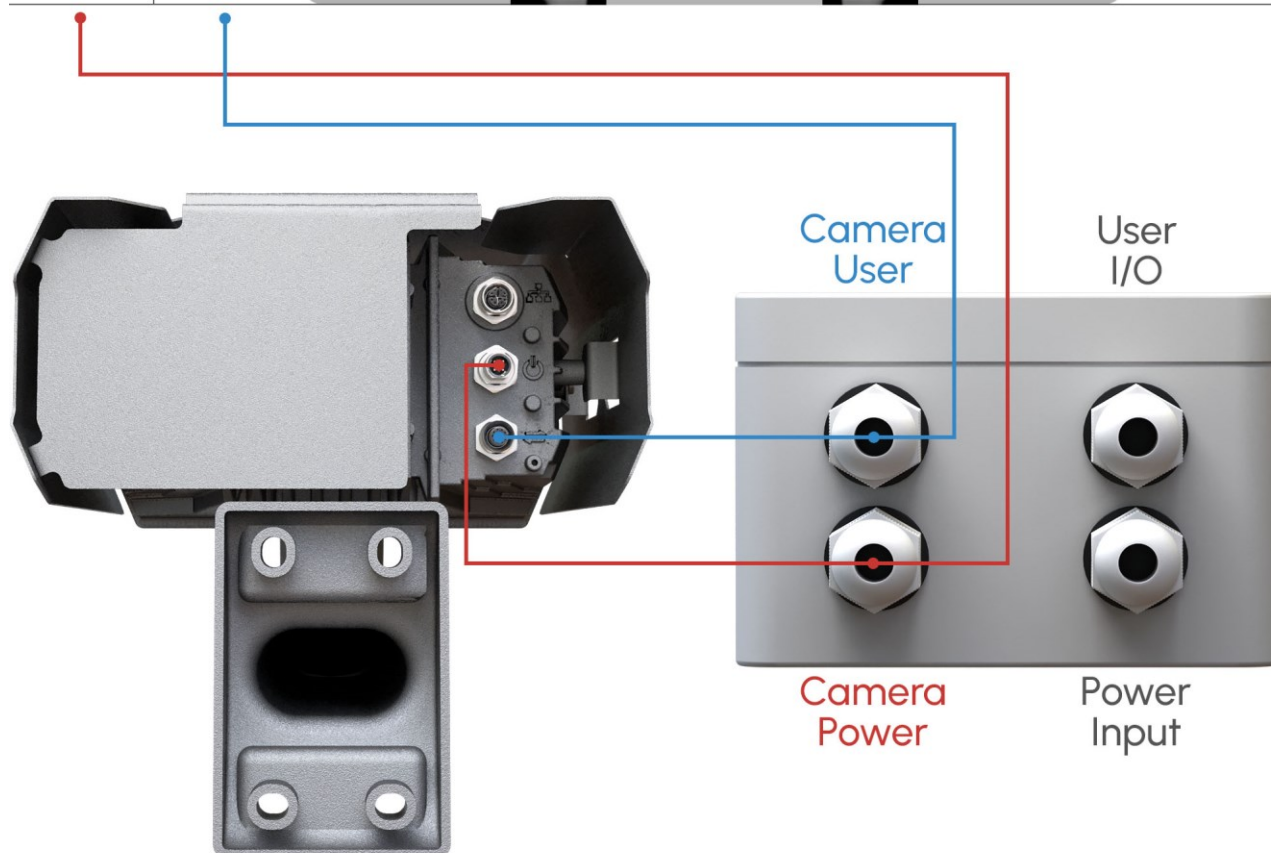

## 6.4. ADDING ALTERNATE IP ADDRESS

### Windows Vista/Windows 7/Windows 10

1. Click **Start** and select **Control Panel**.
2. Open **Network and Sharing Center**.
3. Click **Manage Network Connections** on the left side of Network and Sharing Center.
4. Click on the network connection you want to add an IP address for (to which the camera has been connected) and select **Properties**.
5. Select **Internet Protocol Version 4(TCP/IPv4)**, click on **Properties** and select the **Alternate Configuration** tab.
6. Select **User configured** and enter e.g. the **192.0.2.54 IP address** and **255.255.255.0** as **Subnet mask** as shown on *Figure 1*.
7. Click **OK** in the opened windows.

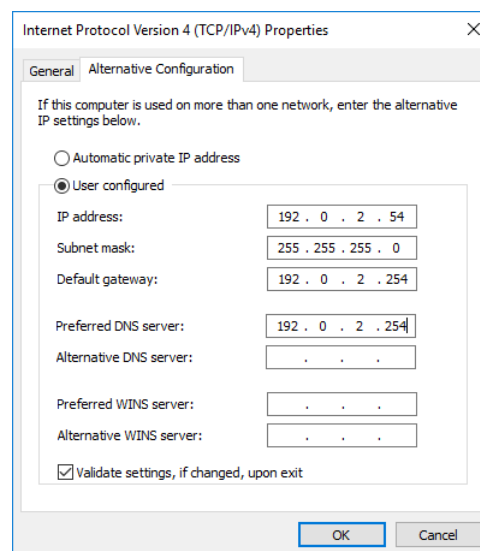

*Figure 1.*

### Linux

1. Open a terminal.
2. Enter the ifconfig command to see the reserved Ethernets (e.g. eth0).
3. Enter the following command: `ifconfig ethY 192.0.2.25`  
where **Y** is a free eth (e.g. eth1) and 192.0.2.25 is a sample IP address.

## 6.5. MAGNETIC RESET

These menu entries restart the camera in normal or in recovery mode. If the web interface is not functional (for example due to a lost IP), Recovery Mode may also be entered applying the magnetic reset procedure.

The **magnetic reset procedure** is as follows:

- Start with a powered off device.
- Place a magnet at the indicated position
- Power on the device (if the magnet is in proper position, the green indicator led on the front of the camera will start flashing very fast)
- Remove the magnet
- Enter the web interface at the 192.0.2.3 (default) IP

### Entering Recovery mode to Vidar camera:

Starting of the Recovery mode can be implemented by magnetization in the following way:

By magnetization:

1. Power off the camera.
2. Touch a magnet (not included) to the back of the camera and hold it in position. See figures below.
3. Power on the camera and wait 5 seconds. If the magnet is in proper position, the green indicator led on the front of the camera will start flashing very fast.
4. Remove the magnet.
5. Reach the camera via its default (192.0.2.3) IP address.

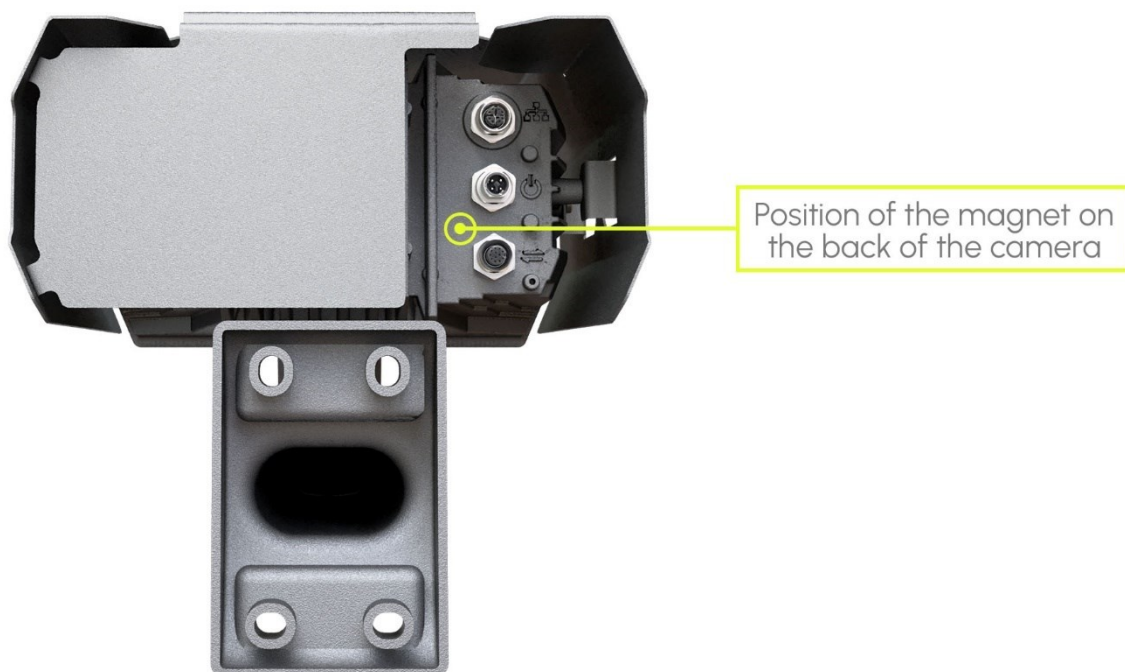

The recommended strength of the magnet is 1210 mT (millitesla).

## 6.6. POSITION OF THE STICKER

Sticker is placed on the bottom of the device.

### Note

The sticker, indicating the Name, IP address, MAC address and the Serial Number of the camera, can be found on a small metal placket at the bottom of the camera.

### CAUTION!

The device is equipped with an infra led illumination unit. The human eye will not or slightly see this light coming from the LED's. Do not look into the illumination unit directly from close range or for more than 100 seconds. Eyes can be damaged by not taking these precautions.

## 6.7. COMPLIANCES

### **CE Certificates:**

The AR FreewayCAM4 ANPR digital camera (VIDAR) family complies with the European CE requirements specified in the EMC Directive 2014/30/EU.

The ANPR cameras conform to the following Product Specifications:

Emission and Immunity:

EN 55032:2015, EN 55024:2010+A1:2015

### **Declaration of RoHS Compliance for Electrical and Electronic Products:**

Adaptive Recognition Hungary ("the Company") hereby declares that the VIDAR ANPR camera family placed on the European Community market by the Company after 1st July 2006 are compliant with EC Directive 2002/95/EC on the Restrict of Certain Hazardous Substances in Electrical and Electronic Equipment (commonly known as the EU RoHS Directive.)

Compliance with RoHS means that where the product falls under the scope of the EU RoHS Directive, the product does not contain the following substances:

- Mercury (Hg) 0.1%
- Lead (Pb) 0.1%
- Cadmium (Cd) 0.01%
- Hexavalent Chromium (Cr+6) 0.1%
- Polybrominated Biphenyls (PBB) 0.1%
- Polybrominated Diphenyl Ethers (PBDE) 0.1%

above the indicated maximum concentration values by weight in homogeneous materials unless the substance is subject to an exemption specified in the Directive or in subsequent Commission Decisions.

This declaration represents the Company's best knowledge, which is partially based on information provided by third party suppliers.

### **Laser safety compliance:**

All models of VIDAR ANPR camera which are equipped with a measuring laser module are Class 1 laser products according to the IEC 60825-1:2014 standard.





## The FCC declaration of conformity

### 47 CFR PART 15 SUBPART B

#### VIDAR

##### **FCC statement**

This device complies with Part 15 of the FCC Rules. Operation is subject to the following two conditions:

This device may not cause harmful interference, and

This device must accept any interference received, including interference that may cause undesired operation.

**Note:** This equipment has been tested and found to comply with the limits for a Class A digital device, pursuant to part 15 of the FCC Rules. These limits are designed to provide reasonable protection against harmful interference when the equipment is operated in a commercial environment. This equipment generates, uses, and can radiate radio frequency energy and, if not installed and used in accordance with the instruction manual, may cause harmful interference to radio communications. Operation of this equipment in a residential area is likely to cause harmful interference in which case the user will be required to correct the interference at his own expense.

Changes or modifications not expressly approved by the manufacturer responsible for compliance could void the user's authority to operate the equipment.

**Warning:** Where shielded interface cables or accessories have been provided with the product or specified additional components or accessories elsewhere defined to be used with the installation of the product, they must be used in order to ensure compliance with FCC. Changes or modifications to product not expressly approved by Adaptive Recognition Hungary could void your right to use or operate your product by the FCC.

## CONTACT INFORMATION

**Headquarters:**

Adaptive Recognition, Hungary Inc.  
Alkotás utca 41 HU  
1123 Budapest Hungary  
Web: [adaptiverecognition.com](http://adaptiverecognition.com)

**Service Address:**

Adaptive Recognition, Hungary Inc.  
Ipari Park HRSZ1113/1 HU  
2074 Perbál Hungary  
Web: [adaptiverecognition.com/support/](http://adaptiverecognition.com/support/)

Adaptive Recognition Hungary Technical Support System (ATSS) is designed to provide you the fastest and most proficient assistance, so you can quickly get back to business.

Information regarding your hardware, latest software updates and manuals are easily accessible for customers via our [Documents Site \(www.adaptiverecognition.com/doc\)](http://www.adaptiverecognition.com/doc) after a quick registration.

### New User

If this is your first online support request, please contact your sales representative to register you in our Support System. More help [here \(www.adaptiverecognition.com/support/\)](http://www.adaptiverecognition.com/support/)!

### Returning User

All registered ATSS customers receive a personal access link via e-mail. If you previously received a confirmation message from ATSS, it contains the embedded link that allows you to securely enter the support site.

