

PARKIT

DIGITAL (IP)
LPR CAMERA

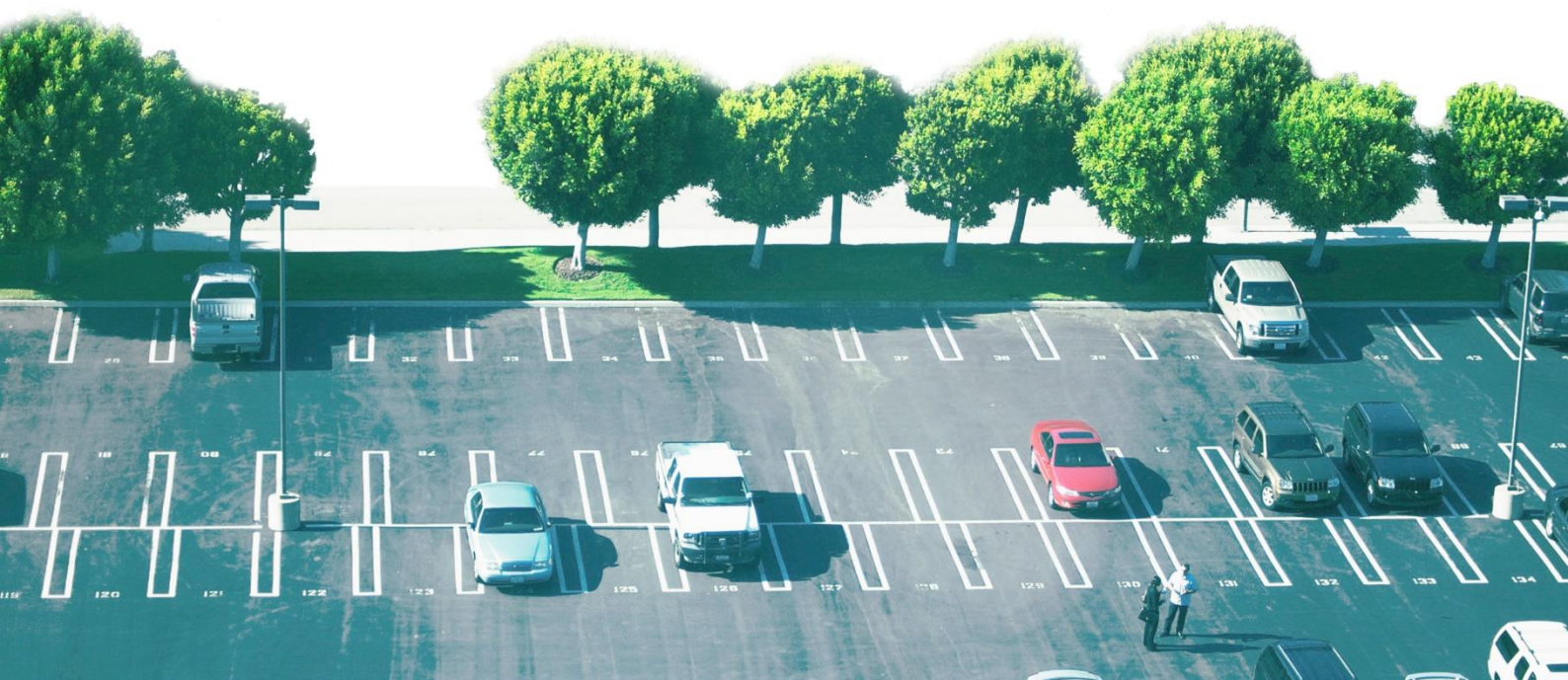

INSTALL GUIDE

For versions from 3.1

Document version: 2016.07.28

Table of Contents

Compliances.....	3
1. Hardware Overview	5
2. Installing the Bracket.....	7
2.1 Mounting	8
3. Setting up the Camera	9
3.1 Power / Trigger/ Serial Connection.....	9
3.2 Ethernet Connection	10
4. Software Requirements	11
5. Accessing the Camera.....	12
6. Recommended Camera Position.....	13
7. Maintenance / Storage.....	15
Appendix	16
Contact Information.....	18

Compliances

CE Certificates:

The ARH ParkIT ANPR digital camera family complies with the European CE requirements specified in the EMC Directive 89/336/EEC.

The ANPR cameras conform to the following Product Specifications:

Emission:

EN 55022, EN 55024

Immunity:

EN 61000-4-2, -3, -4, -5, -6, -8, -11

FCC Compliance:

This product has been tested and found to comply with the limits for a Class A digital device pursuant to Part 15 of the FCC Rules. These limits are designed to provide reasonable protection against harmful interference when the equipment is operated in a commercial environment. This product generates, uses, and can radiate radio frequency energy and, if not installed and used in accordance with the manufacturer's instruction manual, may cause harmful interference with radio communications. Operation of this product in a residential area is likely to cause harmful interference, in which case you will be required to correct the interference at your own expense.

This device complies with Part 15 of the FCC Rules. Operation is subject to the following two conditions:

- 1) This device may not cause harmful interference.
- 2) This device must accept any interference received, including interference that may cause undesired operation.

Notice: The FCC regulations provide that changes or modifications not expressly approved by ARH Inc. could void your authority to operate this equipment.

These limits are designed to provide reasonable protection against harmful interference in a non-residential installation. However, there is no guarantee that interference will not occur in a particular installation. If this equipment does cause harmful interference with radio or television reception, which can be determined by turning the equipment off and on, you are encouraged to try to correct the interference by one or more of the following measures:

- Reorient or relocate the antenna of the radio/television receiver.
- Increase the separation between this equipment and the radio/television receiver.
- Connect the equipment into a different outlet so that the equipment and the radio/television receiver are on different power mains branch circuits.
- Consult a distributor of ARH Inc. or an experienced radio/television technician for additional suggestions.

Declaration of RoHS Compliance for Electrical and Electronic Products:

ARH Inc. ("the Company") hereby declares that the ParkIT ANPR camera family placed on the European Community market by the Company after 8 June 2011 are compliant with EC Directive 2011/65/EU on the Restrict of Certain Hazardous Substances in Electrical and Electronic Equipment (commonly known as the EU RoHS Directive.)

Compliance with RoHS means that where the product falls under the scope of the EU RoHS Directive, the product does not contain the following substances:

- Lead (0,1 %)
- Mercury (0,1 %)
- Cadmium (0,01 %)
- Hexavalent chromium (0,1 %)
- Polybrominated biphenyls (PBB) (0,1 %)
- Polybrominated diphenyl ethers (PBDE) (0,1 %)

above the indicated maximum concentration values by weight in homogeneous materials unless the substance is subject to an exemption specified in the Directive or in subsequent Commission Decisions.

This declaration represents the Company's best knowledge, which is partially based on information provided by third party suppliers."

Equipment modifications:

This equipment must be installed and used according with the instructions given in its documentation. This equipment contains no serviceable components. Unauthorized equipment changes or modifications cause warranty to void.

1. Hardware Overview

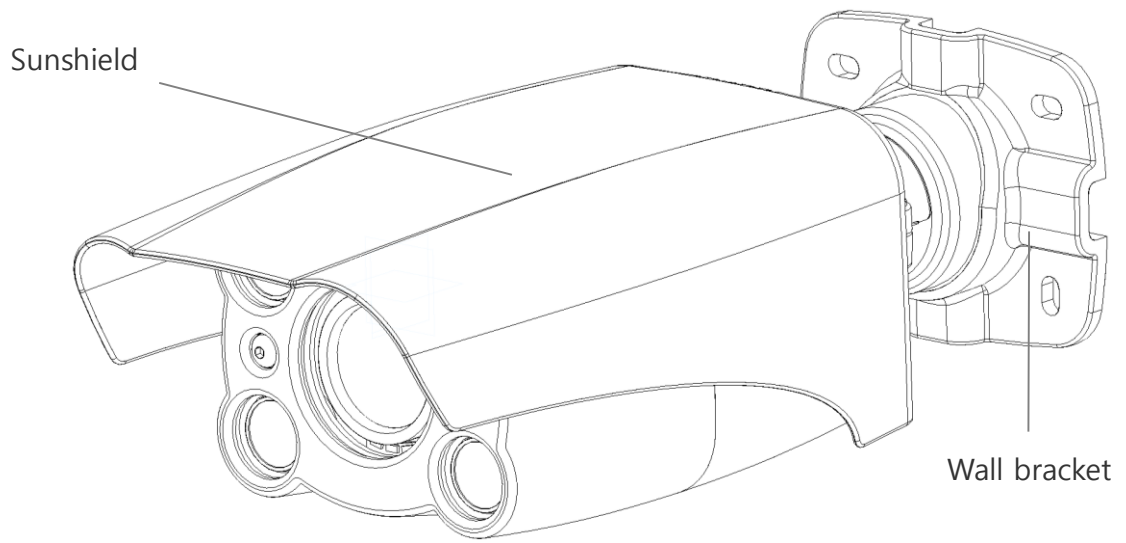

Camera with bracket

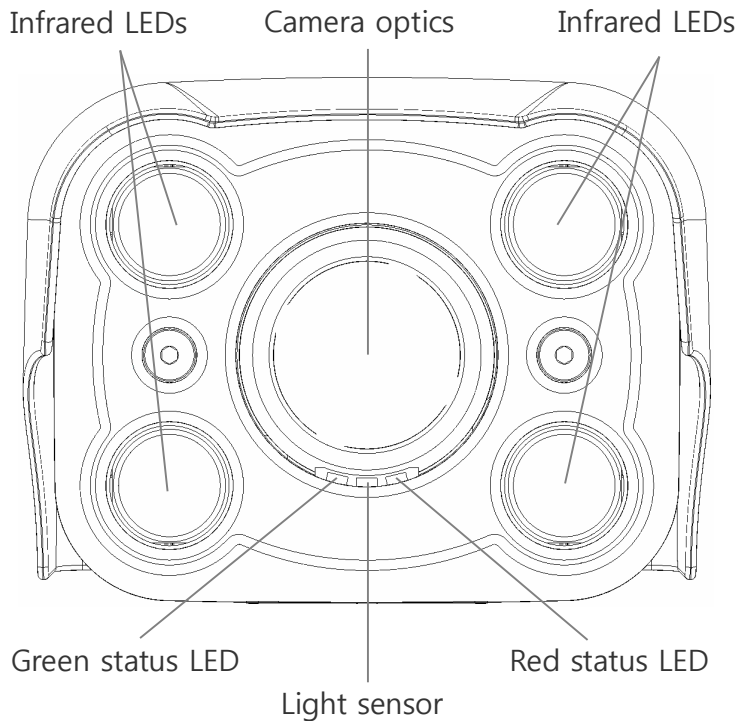

Camera front

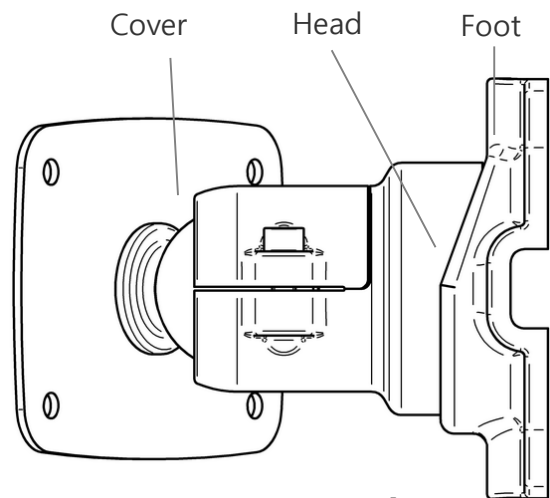

Bracket

Bracket Details and Sizes

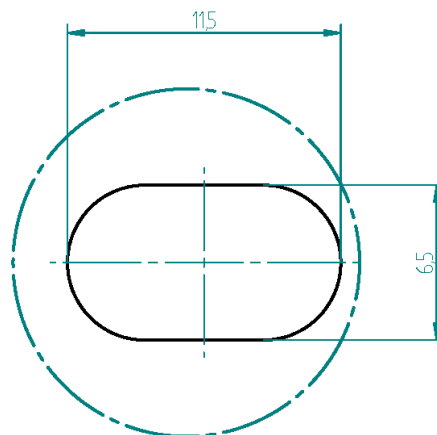
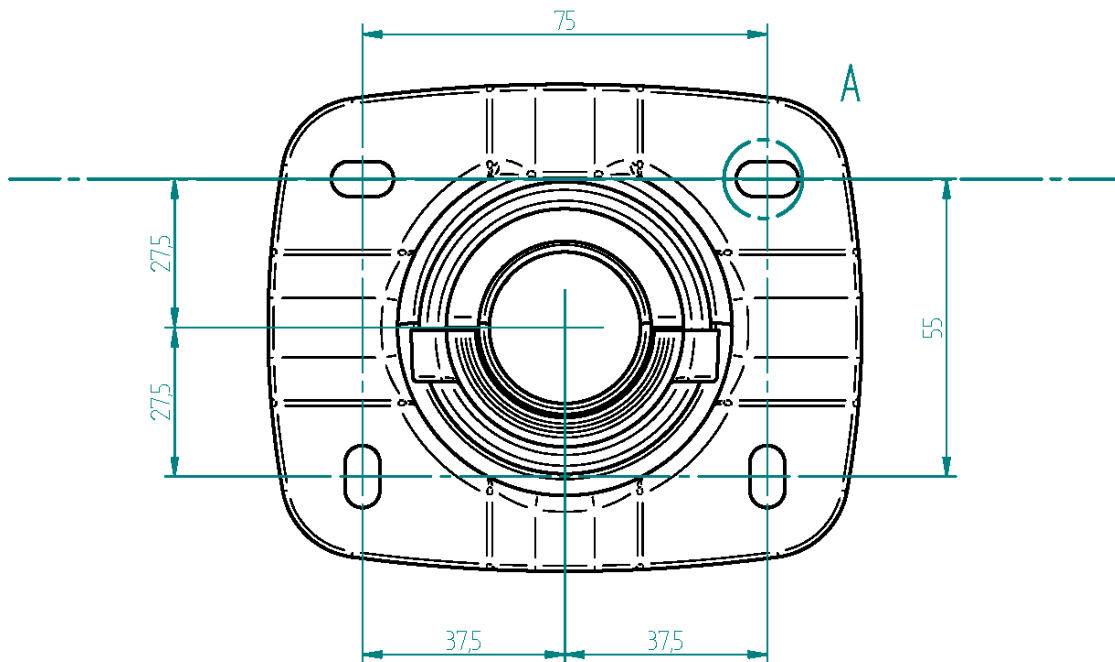
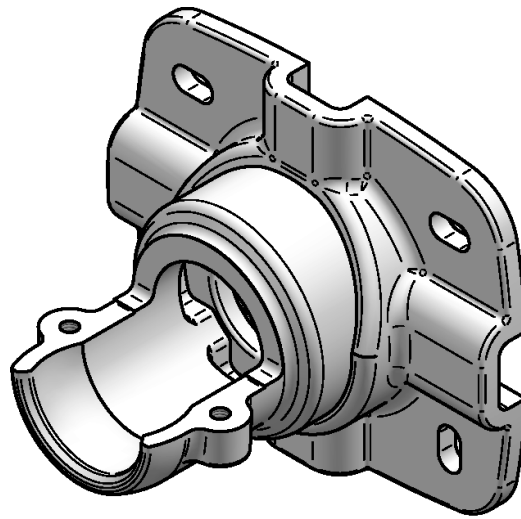

DETAIL A

2. Installing the Bracket

The bracket can be adjusted at two different points:

1. Adjusting the ball joint (A). The bracket allows the ball joint to be rotated in a 35-degree spatial angle in any direction.
2. Adjusting the foot (B). If the necessary extent of rotation exceeds 35 degrees, then the foot of the bracket can be rotated by 180 degrees extending the 35 degree spatial angle by an additional 20 degrees as seen on the figure.

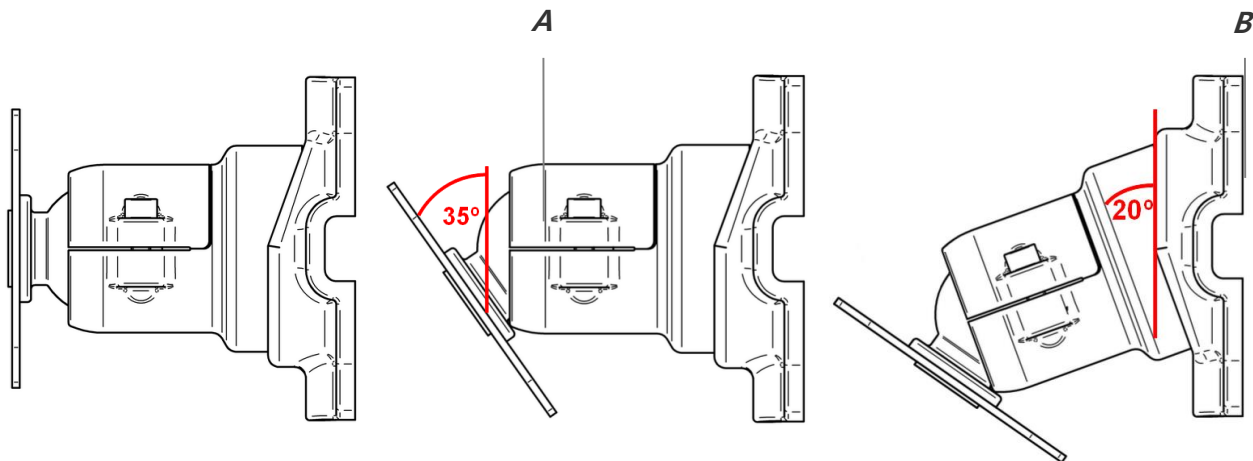

Bracket foot rotated by 180 degrees, which enables the camera to be rotated by an additional 20 degrees.

Steps of rotating the foot

1. Remove the four screws (**1**) located at the back of the foot. (Use a size 4 Allen key).
2. Rotate the foot (**2**) by 180 degrees.
3. Place the screws back into the holes and screw them back on.

Note

Do not overtighten the screws.

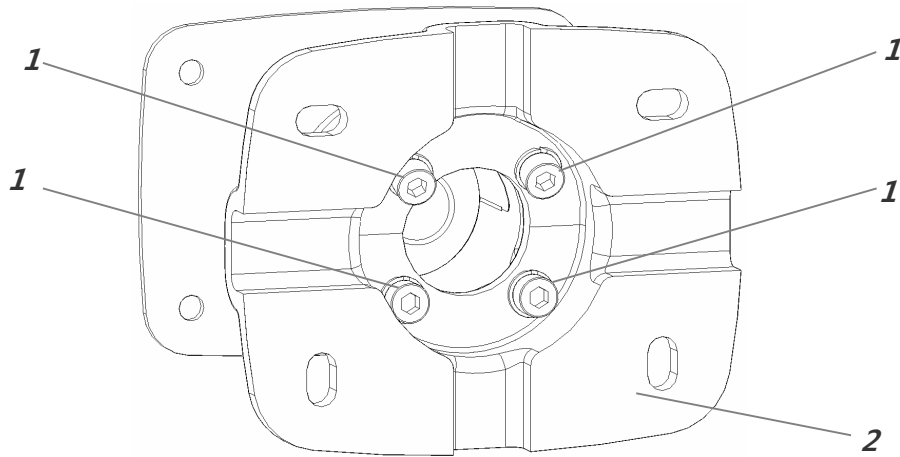

2.1 Mounting

The bracket can be mounted on different surfaces. Use appropriate screws for installation, the surface on which the camera will be mounted determines what screws should be used.

Note

Damages resulting from inappropriate installation void the warranty.

3. Setting up the Camera

Note

Technical specifications are subject to change without prior notice.

The camera is equipped with two cables. The first cable is responsible for the power, trigger and serial connections while the second cable is used for communication via TCP/IP. The lengths of the pre-assembled cables are 1.5 meters and they can be extended (if necessary) according to the following:

- ▶ RJ45: with e.g. inline coupler
- ▶ Power/Trigger/Serial: with e.g. junction box

! Important

For cabling use quality cables certified for outdoor use!
Using improper cables will void the warranty! Water may enter the inside of the camera through loose cable ends. Only use smooth circular cables (6-8mm in diameter).

3.1 Power / Trigger/ Serial Connection

<u>Description</u>	<u>Cable color</u>
1. +12V _{DC}	Red
2. GND.....	Black
3. Opto out G (-)**	Purple/Red
4. Opto out S (+)**	Grey
5. Opto in S (+)*	Brown
6. Opto in G (-)*	Orange
7. NC (no connect).....	Yellow
8. Serial RX***	Green
9. Serial TX***	White
10. Serial GND***	Blue

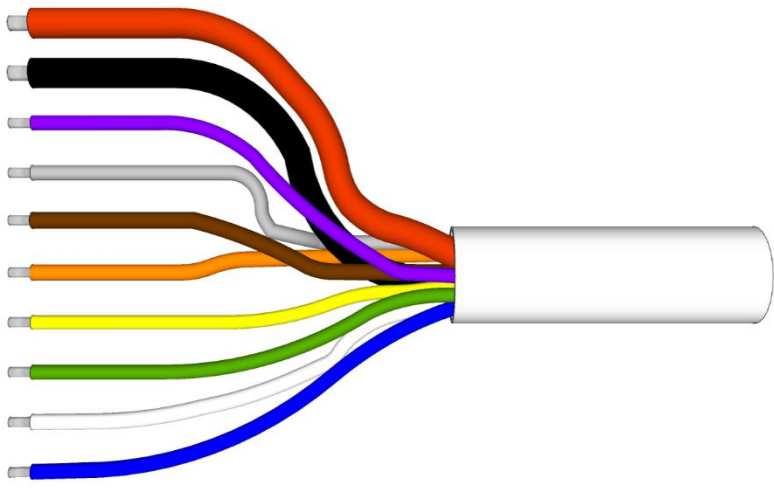

* For trigger input

** For trigger output

*** General-purpose serial port

! Important

Seal the unused cable endings (end sleeves) before connecting to power in order to avoid any damages caused by a possible short circuit.

POWER SPECIFICATIONS:

	ParkIT WideVGA	ParkIT 1.3MP
DC Input	isolated 12V nominal (11V..15V), reverse polarity protected	
Power consumption (max)	12W	14W
Input Current	1.0A (max. 2.5A transients occur for a few msecs)	1.1A (max. 2.5A transients occur for a few msecs)
Over-current Protection	by fuse	

TRIGGER SPECIFICATIONS:

Logic output: Open Collector (max. 12V_{DC}/ max. 10mA)

Input: min. 5V, max. 12V

Pulse width: min. 1 ms

SERIAL CONNECTION:

The serial port of the camera complies with the RS 232 standard.

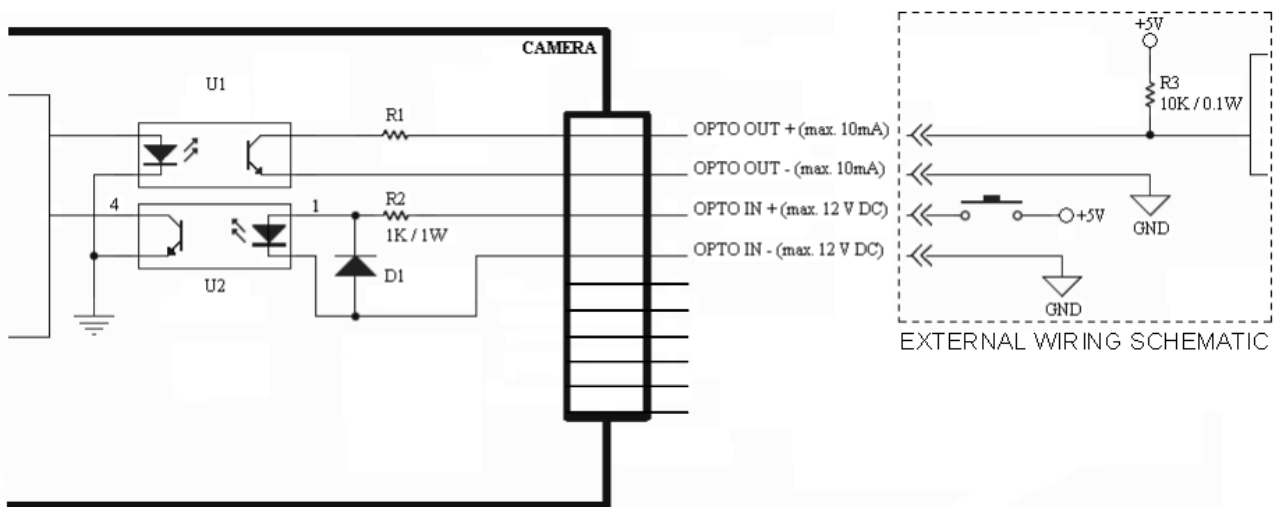

Sample application for trigger input and output

3.2 Ethernet Connection

The camera is equipped with CAT5e UTP crossover cable with RJ45 plug. It is ready to connect both to a PC and a network switch directly.

Note

The RJ45 plug is not weatherproof.

4. Software Requirements

The ParkIT camera is developed to operate without any kind of special software.

Software requirements

- For network setup, administrator (root) privileges are necessary.
- Web browser: Mozilla Firefox 4, Internet Explorer 8, Google Chrome version 14.X.X.X or later. If possible, update your browser (Firefox or Chrome) to the latest available version.

Note

To enable all camera functions, enable JavaScript and ActiveX controls in your browser.

5. Accessing the Camera

Steps of accessing the web interface of the camera from a browser:

1. Connect the camera to a computer or network switch, then power on the camera. After it is turned on, both status LEDs (red and green on the front of the camera) will turn on while the camera is booting. After it has finished booting, the green status LED flashes two times signaling that the camera is ready for operation.



2. Enter an alternate IP address (or set your computer's IP) in the 192.0.2.x subnet – where x is an integer number between 1 and 254 **except 3** – with the subnet mask of 255.255.255.0. For more information, see the [Appendix](#)

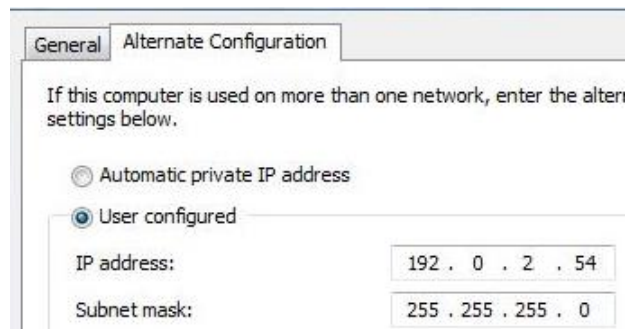

3. Use the **ping command** to test the communication with the camera

Windows:

```
C:\>ping -t 192.0.2.3
```

Linux:

```
username@mylinux:~$ ping 192.0.2.3
```

4. After a short while the ping package should return: **Reply from 192.0.2.3**. If not:
 - o first check the Ethernet LEDs on the PC or the switch
 - o check whether the IP address is set correctly; the IP address of the PC can be pinged.
 - o check that the proxy is set in that the browser or the browser is not set to offline.

If these obstacles are checked and there is still no reply, power the device off, turn it back on and enter the previous ping command again.

5. **Start a browser** then enter the default IP address of the camera into the address bar (<http://192.0.2.3>). Once this is done, the camera starts with administrator privileges, ready for setup and configuration.

6. Recommended Camera Position

A good ANPR engine can read the plates from images taken in various conditions. However, if you want to achieve recognition rates of over 95% with short recognition times, you have to calculate the position of the camera accurately. The best position is if the angle between the camera axis and the direction of the vehicle movement is minimal. Furthermore, the camera should be installed 1 – 1.5 meters above the headlights of the vehicles.

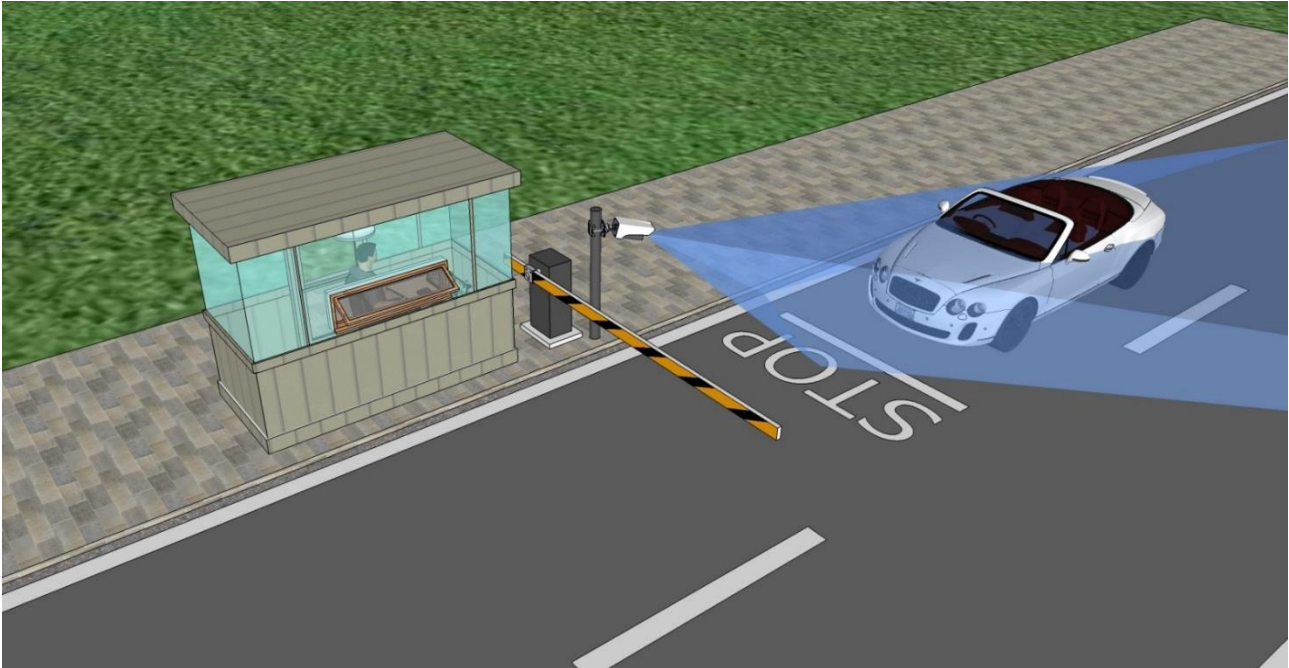

The distance between the camera and plate is also important. If the camera is too far from the plate, the characters may not be large enough for recognition. In this case, zoom-in until you reach the proper size. If the distance is too short, it may happen that a part of the plate will be outside the camera's field of view (when the vehicle is near the side of the lane or the plate is not centered on the vehicle).

In terms of ANPR/LPR, the size of the characters on the image is the most important. For Latin characters it is recommended to have at least a 16 pixel average character height, for Arabic or other special characters it is recommended to have a height of 20 pixels (this is due to the fact that these characters are more calligraphic than English characters). Characters that are too large are also not suitable for ANPR; therefore, try to avoid settings where the character size is greater than 50 pixels in height. The line width of a character on the image should be at least 2 pixels.



Correct camera position

Do not rotate the camera any direction from the horizontal position!

A properly set camera should provide a similar image:



A proper sample image

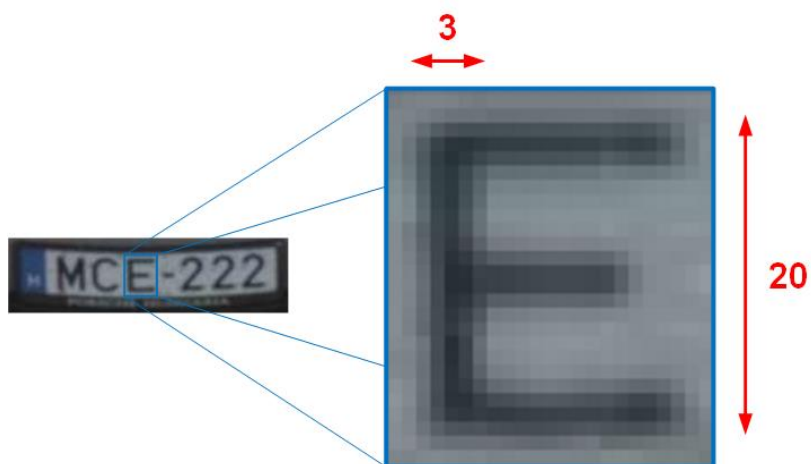

Proper character sizes (in pixels) on the sample image

7. Maintenance / Storage

The cameras are designed to operate 24/7/365 under all weather conditions without the need for special maintenance. Please keep the front of the camera clean. During the cleaning process make sure that you do not scratch the front cover.

Never use the camera without its sunshield as it was specially designed to protect the device against environmental effects such as heat, moisture or contamination.

The cameras should be stored in a low humidity environment in the temperature range of -35 °C to +55°C.

Note

The startup temperature of the camera is -20 °C.

The maintenance of the devices is recommended on a quarterly basis.

During maintenance, make sure that:

- the camera operates properly,
- it is facing in the previously set direction,
- the fastenings are not loose,
- the front of the camera and the camera itself is clean (no spider webs or any other contaminants inhibit the visibility),
- the mechanical components and parts are not damaged in any way

Appendix

Adding an Alternate IP Address

Windows 7 / Windows 8

1. Click **Start** and select **Control Panel**.

Select either the **Small icons** or **Large icons** option from the **View by** drop-down menu which is found on the upper right hand side of the window.

2. Open **Network and Sharing Center**.
3. Click on **Change adapter settings** (Win 7/8) on the left side of Network and Sharing Center.
4. Right click on the network connection you want to add an IP address to (the one the camera has been connected to) and select **Properties**.

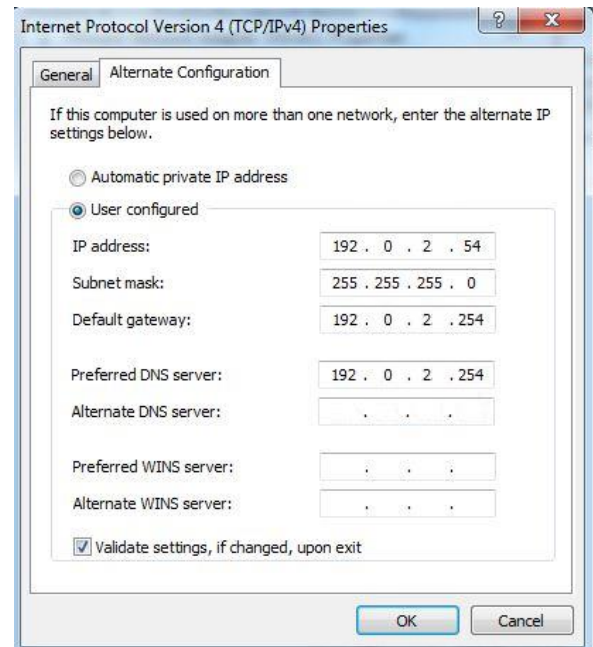

Figure 1

5. Look for Internet **Protocol Version 4 (TCP/IP v4)** and press the **Properties** button.
6. Select **Obtain an IP address automatically** and click on the **Alternate Configuration** tab.
1. Select **User configured** and enter an **IP address** (e.g.:192.0.2.54). The **Subnet mask** should be 255.255.255.0 as shown in *Figure 1*.
2. Click **OK** in the opened windows to close them.

Linux

1. Open a terminal.
2. Enter the ifconfig command to see the reserved Ethernets (e.g. eth0).
3. Enter the following command: `ifconfig ethY 192.0.2.25`
where **Y** is a free eth (e.g. eth1) and 192.0.2.25 is a sample IP address.

Position of the sticker



The sticker indicating the Name, IP address, MAC address and the Serial Number of the camera, can be found on the bottom of the device.

! Important

The device is equipped with an 850nm InfraRed illumination unit. The human eye will not or slightly see this light coming from the LED's. Do not look into the illumination unit directly from close range or for more than 100 seconds. If you do not take these safety precautions, you risk damaging your eyes.

Contact Information

Headquarters:

ARH Inc.
Alkotás utca 41
HU-1123 Budapest
Hungary
Phone: +36 1 201 9650
Fax: +36 1 201 9651
Web: www.arh.hu

ARH America:

ARH America Corp.
28059 US Highway 19 North Suite
203
Clearwater, FL 33761
Phone: (727) 724-4219
Fax: (727) 724-4290
Web: www.adaptiverecognition.com

Service Address:

ARH Inc.
Ipari Park HRSZ
1113/1
HU-2074 Perbál
Hungary
Phone: +36 1 2019650

ARH Technical Support System (ATSS) is designed to provide you the fastest and most proficient assistance, so you can quickly get back to business.

Information regarding hardware, software, manuals and FAQ are easily accessible for customers who previously registered to enter the dedicated ATSS site. Besides offering assistance, the site is also designed to provide maximum protection while managing your business information and technical solutions utilized.

New User

If this is your first online support request, please create an account by clicking on this [link](#).

Returning User

All registered ATSS customers receive a personal access link via e-mail. If you previously received a confirmation message from ATSS, it contains the embedded link that allows you to securely enter the support site.

If you need assistance with login or registration, please contact atsshhelp@arh.hu for help.